

WISE-2410SK

LoRaWAN Wireless Condition Monitoring Starter Kit

NEW



CE FCC 

Features

- LoRaWAN wireless connectivity
- Built-in 3-axis accelerometer and temperature sensor
- On-board computing. Directly sends VRMS, ARMS, Peak, Displacement, Kurtosis, Crest factor, Skewness and Standard Deviation values to applications
- Support battery power supply, no wiring installation needed
- Easy settings with user friendly interfaces on WISE Studio utility
- ISO 10816-1 compliant
- Support wide temperature -20 ~ 80 °C (Battery-powered)
- IP66 enclosure design

Introduction

WISE-2410 is a LoRaWAN wireless condition monitoring sensor integrated with an ARM Cortex-M4 processor, LoRa transceiver, 3-axis accelerometer and temperature sensor. It balances the wireless bandwidth between WISE-2410 and the gateway, so it also mitigates the data transmission fail rates between edge-devices and gateways.

Star Topology

WISE-2410 uses a star network topology and features a gateway data relay function between sensors and the application server. The communication between the sensors and gateway goes over the wireless channel, utilizing the LoRa physical layer, whilst the connection between the gateways and the central server are handled over a backbone IP-based network or over Modbus protocol to the application server.

Computing on Board

With an ARM Cortex-M4 Processor, WISE-2410 enables users to implement more features inside. WISE-2410 is able to calculate more complex eigenvalues itself, such as VRMS, ARMS, Peak, Displacement, Kurtosis, Crest factor, Skewness and Standard Deviation values. With its edge computing capability, WISE-2410 can balance the loading between WISE-2410, gateway, and cloud service.

Plug & Play with 2-year Battery life cycle

WISE-2410 includes two 3.6V AA battery holders. Along with LPWAN technology verified by Advantech, the battery life on WISE-2410 can be up to 2 years with once per hour data update interval time. With IP66 protection design, WISE-2410 is ideal for Low-Power Wide-Area Network (LPWAN) applications, such as pumps, HVAC system, motors, facility monitoring and more. WISE-2410 connects to Advantech's WISE Studio Utility for more user friendly and efficient installation.

Dimensions

Unit: mm

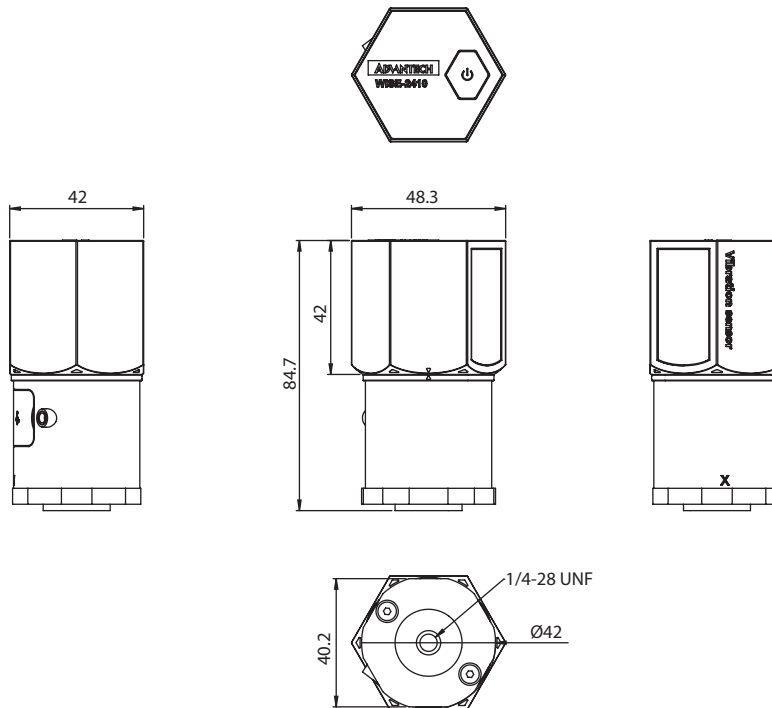

Common Specification of WISE-2410

Wireless Communication

- **Frequency Band** US 902-928 (MHz)
- **Spreading Factor** 7~12
- **Transmit Power** Up to 20dBm
- **Topology** Star (LoRa/LoRaWAN)
- **Sensitivity** -148dB
- **Data Rate** 21.9 kbps at SF7 mode US

General

- **Power Input** 3.6V AA Battery *2pcs (Not included)
- **Battery Life** 2 years (once per hour data update interval time)
- **LED Indicator** Power, Tx
- **Configuration Interface** Micro-B USB
- **IP Class** IP66
- **Mounting** Stud mount, Mounting pad and Adhesives
- **Dimension (H x D)** 84.7 x 48.3 mm
- **Certification** CE (RED), FCC

Environment

- **Operating Temperature** -20°C ~ 80°C (Battery powered)
- **Operating Humidity** 10% ~ 95% RH
- **Storage Temperature** -25°C ~ 90°C
- **Storage Humidity** 5% ~ 95% RH

3-Axis Accelerometer Sensor

- **Axis** X-Y-Z
- **Frequency Range** 10~1000Hz
- **Amplitude Range** ±16g
- **Statistical Time-Domain** Velocity RMS, Acceleration (RMS & peak), Displacement, Kurtosis, Crest factor, Skewness, Standard deviation
- **Output Data Rate** 6600Hz
- **Resolution** 10 bit (all g range)
- **Accuracy (FC =100Hz)** Under 5%
- **Noise (MAX. TA = 25°C. 0g)** ±40mg
- **Nonlinearity** ±0.5 %
- **Cross-Axis Sensitivity** ±1 %
- **Sensitivity Change Due to Temperature** ±0.02 %/°C

Temperature Sensor

- **Measurement Range** -20°C ~ 120°C
- **Accuracy** -2°C with 85°C (TA = 27°C, Directly contact with heat source (Metal Base of WISE-2410))

Ordering Information

Smart Condition Monitoring Sensor

- **WISE-2410SK-NA** Wireless Smart Condition Monitoring Sensor Starter Kit -US 902-928 (MHz)